

# SL 系列全铜镀镍插入接头式单向节流阀

## 规格表

管径	Ø4,Ø6,Ø8,Ø10,Ø12				
使用流体	空气				
使用压力范围	0.095-1.6MPa				
保证耐压力	1.6MPa				
保证真空压力	-100Kpa(10Torr)				
螺杆回转载数	10(8) 转 Turn				
使用温度范围	5-100°C				
材料	主体	不锈钢			
连接口径 Rc (PT)	M5x0.8p	1/8"	1/4"	3/8"	1/2"
牙部涂胶	附涂胶印				

SL排气控制(标准型) SL Exhaust Control(Standard Type)

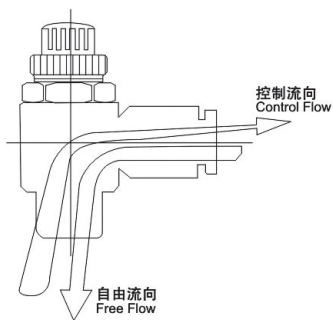

SL-B进气控制 SSLT-B Intake Control

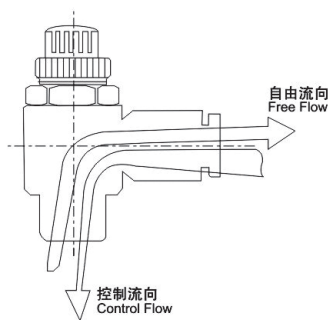

## PC- 终端金属接头

规格	L1	L2	S1	H	S	T	D1	D2
PC4-M5	19	-	2	3.6	8	M5	Ø8	Ø4
PC4-01	16	-	2.5	7	10	R1/8	Ø8	Ø4
PC4-02	18	-	2.5	9	14	R1/4	Ø8	Ø4
PC4-03	19	-	2.5	9.5	17	R3/8	Ø8	Ø4
PC6-M5	26	-	2	4	12	M5	Ø12	Ø6
PC6-01	25	-	5	7	12	R1/8	Ø12	Ø6
PC6-02	20.5	-	5	9	14	R1/4	Ø12	Ø6
PC6-03	20.5	-	5	9.5	17	R3/8	Ø12	Ø6
PC6-04	21	-	5	11	21	R1/2	Ø12	Ø6
PC8-M5	28	-	2	4	14	M5	Ø14	Ø8
PC8-01	28.5	-	5	7	14	R1/8	Ø14	Ø8
PC8-02	28.5	-	6	9	14	R1/4	Ø14	Ø8
PC8-03	22	-	6	9.5	17	R3/8	Ø14	Ø8
PC8-04	22	-	6	11	21	R1/2	Ø14	Ø8
PC10-01	30.5	-	5	7	17	R1/8	Ø16	Ø10
PC10-02	30	-	6	9	17	R1/4	Ø16	Ø10
PC10-03	25	-	8	9.5	17	R3/8	Ø16	Ø10
PC10-04	24	-	8	11	21	R1/2	Ø16	Ø10
PC12-01	31	-	5	7	19	R1/8	Ø18	Ø12
PC12-02	33	-	6	9	19	R1/4	Ø18	Ø12
PC12-03	31	-	10	9.5	19	R3/8	Ø18	Ø12
PC12-04	24	-	10	11	21	R1/2	Ø18	Ø12
PC14-02	-	-	-	-	-	-	-	-
PC14-03	-	-	-	-	-	-	-	-
PC14-04	-	-	-	-	-	-	-	-
PC14-06	-	-	-	-	-	-	-	-
PC16-02	-	-	-	-	-	-	-	-
PC16-03	-	-	-	-	-	-	-	-
PC16-04	-	-	-	-	-	-	-	-
PC16-06	-	-	-	-	-	-	-	-

